



Mechanical Installation Insert

Xunlight Photovoltaic Laminates Adhered to Standing Seam or Other Metal Roofing Products



Contact:
Jim Young
Xunlight Corporation
3145 Nebraska Ave.
Toledo, Ohio 43607
Ph +1(419) 469-8690
Fax +1(419) 469-8601

Introduction

Xunlight Corporation is a manufacturer of flexible , lightweight and environmentally safe thin-film silicon solar laminates. Due to the unique composition of our advanced thin-film applications, our laminates can be utilized in a wide-variety of ways. The combination of flexible and lightweight allows for the implementation of small- to large-scale energy generation strategies for a variety of applications. Xunlight Laminates are designed to be versatile long-lasting solar laminates which can be installed directly onto commercial standing seam metal roofs or to other metal sheets products such as coiled Galvalume/Zincalume. The metal sheets can then be attached to the roof or other structures. The metal substrate can either be Kynar (PVDF) coated metal or uncoated Galvalume/Zincalume. If your metal roofing material is not known care should be taken to ensure proper adherence of the laminate to the material. There must be adequate flat area to accommodate the laminate.

Several other installation methods for terrestrial, commercial, and residential rooftops applications are available, Please visit WWW.Xunlight.com for more information.

DISCLAIMER of LIABILITY

Prior to installation you must first read Xunlight's catalog #IM1 for general safety and Liability information.

Please contact Jim Young prior to starting the installation (See cover page for contact information)

This catalog is for your reference only, please visit WWW.Xunlight.com for the latest version of this and all other Xunlight product catalogs prior to installation.

XUNLIGHT reserves the right to make changes to the product, specifications, data sheets and manuals without prior notice.

- **Safety Warnings**

Xunlight laminates are designed for terrestrial, commercial, industrial, and residential rooftop applications. The installation instructions are related specifically for the use of Xunlight Laminates in conjunction with standing seam metal roofs or similar metal roofing material such as Galvalume/Zincalume coiled material.

- Do not puncture, cut, or alter the Xunlight laminate in any way. Doing so could result in electrical shock, may cause a fire, and will void the warranty, and all Xunlight Safety Certifications for this product will be invalidated. There is no field serviceable components, or components that can be field altered in a Xunlight laminate.

Installation Instructions.

Installation Instructions.

These installation instructions are specifically for use of Xunlight laminates directly adhered to a standing seam metal roofs or other similar metal product. Before starting any installation, review the label supplied on each laminate for electrical specifications, system design specifications and warnings or cautions.

Installation Considerations --Before installing the Xunlight laminates a site survey should be performed. Sites should be selected in areas providing full direct sunlight, especially during the middle of the day, when the sun is the highest. An area large enough for the array must be identified. It should be flat, clean, well drained, and free of shadows. A minimum pitch of ¼ inch per foot is required to prevent ponding. Areas showing evidence of previous ponding should be repaired prior to installation of the laminate. Due to the many different types of roofing materials and designs there are several variations to applying the Xunlight laminates to the roofing material. This guide will cover the general installation techniques for the most common types of installations. However please contact a local professional engineer to perform a wind uplift study prior to the installation so a detailed plan can be established to ensure the proper installation technique and mounting arrangement is used.

A rooftop system installation will typically include wire-ways, conduits, combiner boxes, over current protection devices, and inverters. The specification and installation of these system components are not covered in this document. A qualified professional, NABCEP certified installer or licensed electrician should design and install Xunlight laminate systems in accordance with all national and local codes and regulations. Do not design or install a system that exceeds the fuse, voltage, or current ratings on the label of a Xunlight laminate.

Laminate Handling -- Care should be taken while handling the Xunlight laminates. A cardboard core is provided in the box of laminates and it is an essential tool in removing and transporting the laminate to the installation position. To remove a laminate turn core and wrap the laminate around the core while turning the core inside the box. Two installers should then pull the core with the laminate wrapped around it out of the box; at least one installer should be holding the short edge of the laminate to the core so that it does not unroll prematurely. Carry the laminate on the core to its installation position.

Required Tools -- Below is a list of the required tools to install the entire line of Xunlight laminates on TPO and EPDM roofs.



Tools needed:

- a. Chalk line
- b. Gloves
- c. Scissors
- d. Tape measures
- e. Manufacturer Recommended primer applicator
- f. Razor knife
- g. Firestone Quick Prime Plus (for Xunlight laminates)
- h. ADCO Heliobond PVA600BT
- i. Isopropanol, rags
- j. Indelible markers
- k. Rubber roller
- l. 3M #4110 Acrylic Tape 1inch (25mm) wide.

Mechanical Installation Layout and Prep work --

The mechanical means for securing the laminate to the roof is the application of 4 inch wide ADCO Heliobond PVA 600BT (butyl) seam tape and 3M #4110 (acrylic) tape adhered to the roofing material. However each installation site is unique and should have a wind uplift study included in the site survey. The hold strength of seam tape is available upon request. Below is an illustration of a **perpendicular** tape layout for flat metal roofing material. Tape is applied to the roofing membrane full length of the array **perpendicular** to the length of the laminates. The header and footer tapes should be the 1" acrylic tape extend past the laminate slightly with the butyl tape adhered directly to the inside. This insures that the edge of the laminate will not extend past the edge of the tape during the installation process. The center of the laminates should have additional, evenly spaced strips of butyl tape to achieve a maximum distance of 34" between each strip of tape. In the illustration XR36 laminates are shown which require 7 strips of tape to achieve the 34" maximum tape spacing. For installations where there are obstructions like the raised seams on a standing seam metal roof it is appropriate to apply the butyl tape **parallel** to the length of the laminate with the acrylic tape at the header and footer end with slight amount of tape exposed. For the XRU and XRS series laminate butyl tape at each edge will suffice for the XR series laminates an additional strip of butyl tape on the center of the laminate is required. Be sure to apply the butyl tape leaving the tape slightly exposed on the edges so the edge of the laminate is fully adhered. Leave a 1/2" (12mm) space on the acrylic tape at the lower edge of the laminate for a weep hole to allow condensation to exit. The temperature must be above 50°F for the tape to adhere properly.

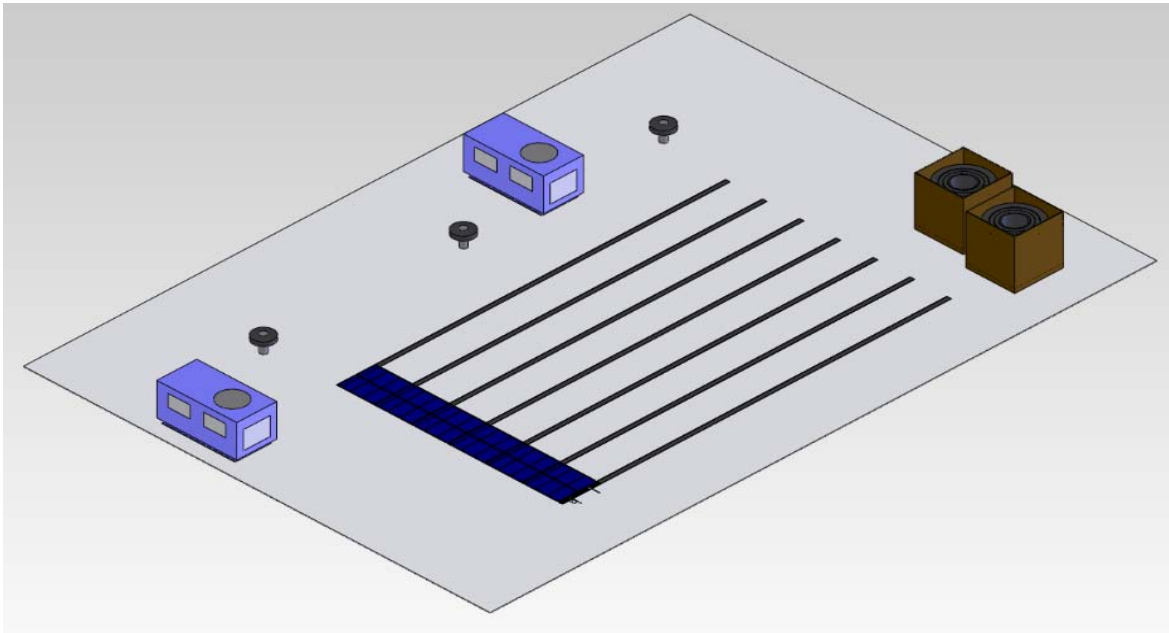

Once the locations of the laminates and corresponding tape is determined snap chalk lines according to the tape layout requirements stated above. Clean the roofing material, per the manufacturer's current technical specifications where the tape will be placed. Allow the roof to dry completely, apply the manufacturers recommended primer to the cleaned areas of the roof. Allow the primer adequate time to cure. It may be necessary to re-snap chalk lines prior to applying the tape to the roof. Step by step detailed instructions are to follow

Step by Step Laminate Installation Instructions

1. Measure key reference points where tape will be applied and mark with indelible marker. Snap chalk lines at reference points to guide the installation of the laminates.
2. Clean area where adhesive tape is to be installed. Use isopropanol or roofing manufacturer's recommended cleaning solution for difficult to remove materials.
3. Apply primer (Firestone Quick Prime Plus) to the laminates. The primer on the laminates must correspond to the tape pattern of the roofing substrate.
4. Apply the roofing manufacturers recommended Primer to the roofing material using the manufacturers recommended applicator in the appropriate configuration using the chalk lines as a guide. The location of the primer must correspond with the primer applied to the laminates
5. Once the primer has set up install the adhesive tape to the primed locations of the roofing material using your chalk lines as a guide. Apply the tape the full length of the array and cut the tape to length. Use the rubberized roller to ensure proper adhesion to the roof.
6. Now you are ready to install the laminates, with the tape's release film still applied, use the cardboard core provided to carefully unroll the laminate into its approximate position. Using the chalk lines as guides, position the laminate into its final position.
7. Pull the tape's release film on the junction box end of the laminate. Press the laminate into the tape to adhere the laminate to the roof. This will ensure the laminate does not get moved from its proper position for the remainder of the steps. In the case of standing seam or similar **parallel** tape application roofs remove the acrylic tape's liner and approximately 2 foot of the release films on the butyl tape on the header side of the laminate.
8. For **perpendicular** installations start from the non adhered end of the laminate roll the laminate back on to the cardboard core exposing the remainder of the tape. Peel away the tape's release films as you unroll the laminate off of the cardboard core. Keep a constant tension on the core as you unroll the laminate to ensure the laminates lay flat. For **parallel** installations it is not necessary to roll the laminate back on to the core, simply peel off the remainder of the release liner.
9. Press the adhesive tape that is under the installed laminate using the rubberized roller. Use between 5 and 10 pounds of pressure. This will create the proper adhesion between the laminate and the tape. For **perpendicular** tape applications Trim the release film leaving enough to have an overlap between the film and the previously installed laminate. This will stop the laminates from prematurely sticking to the tape during the alignment of the next laminate that is to be installed.
10. Continue installing the laminates in this fashion until the array is completed.

Laminate Interconnection – Xunlight laminates are supplied with factory installed Tyco SOLARLOK connectors. The factory installed wires are 12 AWG [4 mm²] copper UL-listed PV-wire which is rated for 90°C. Series strings of laminates may be directly attached together using these connectors.

At the ends of series strings, Tyco SOLARLOK connectors should be attached to USE-2 or PV-Wire that has been certified by Tyco to conform to the requirements of UL-1703 in combination with these connectors. At the publication date of this manual, the instructions for field wiring with Tyco connectors is provided in Tyco Technical Bulletin 1654268-1, Issued 05-2007. The Installer should always acquire a new copy of this document from www.tycoelectronics.com for each installation. The Tyco Part Number for the male connector is 6-1394461-2. The Tyco Part Number for the female connector is 1394462-3. SOLARLOK assemblies are not designed to be used as laminate disconnects. National and local codes applying to wire size and selection should be observed and the correct tools and crimp contacts should be utilized according to the Tyco Field Application Manual.

Do not cut off the factory supplied connectors to field wire the laminates. This will void the Warranty and all Xunlight Safety Certifications for this product will be invalidated.

Laminate Disconnect and Removal

In the event that a Xunlight laminate needs to be removed or replaced use the following procedures. A certified electrician is required for the electrical servicing of the system.

1. Use shut down procedure provided in the electrical system documentation.
2. Make sure your shoes are clean and free of debris.
3. If it is necessary to walk on the laminates use a high voltage rubber mat.
4. Cover adjacent laminates with an opaque material such as cardboard
5. Unplug the necessary connectors.
6. Short out laminate to be removed and adjacent laminates
7. Using a heat gun, heat the top of the laminate above the adhered area use a metal scraper placed between the top of the adhesive tape and the back sheet of the laminate and while moderately pulling on the laminate use the scraper to help release the laminate from the tape, use the heat gun to melt the adhesive while pulling.
8. To install a new laminate follow the installation steps in this insert.

9. Specifications and Support Documents



Designing and Manufacturing Adhesive & Sealant Solutions

PVA 600BT PV Module Installation Tape Product Data Sheet

Description:

PVA 600BT is an extruded black rubber adhesive tape designed to provide high strength, watertight attachment of PV modules and PV pre-assemblies to single ply EPDM, TPO and metal roofing panels. It is also suitable for use on properly prepared granulated and non-granulated modified bitumen roofing. PVA 600BT is soft and tacky for quick grab to roof membranes, yet possesses high initial strength at 158°F (70°C). PVA 600BT also exhibits excellent adhesion to polar and non-polar substrates such as glass, metals, wood, concrete, masonry and plastics.

Features	Benefits
UL and FM Approved	Code Approvals
Environmentally Safe	No VOC's
Lowers Labor Costs	Decreases Application Time
Safety Benefits	No Solvents or Torch Needed
Excellent Tack	Quick Stick

Basic Use:

For adhering flexible PV modules and PV pre-assemblies to EPDM and TPO membrane roofing.

Application Instructions:

Refer to ADCO Products, Inc. application procedures.

Limitations:

Talc, dust, oil, ice, snow or wet conditions inhibit good adhesion. Clean and dry surfaces are a necessity.

Health & Safety:

Users must follow individual product data sheet and Material Safety Data Sheets (M.S.D.S.) for health and safety precautions. Always use protective eyewear.

Availability/Cost:

Availability and cost can be obtained from your local ADCO Products, Inc. representative or distributor.

PVA 600BT
2/08

Technical Data		
Physical Properties		
	<i>Typical Values</i>	<i>Test Method</i>
Color	Black	Visual
Permeability	0.6 Perm-Mils	ASTM E 96
Hardness	110 dmm	ASTM D 217
Ash Content	16%	ASTM D 297
Brittleness Temperature	-50°F	ASTM D 746
Solids Content	98%	ASTM C 681
Tensile Adhesive Strength	35 psi (alum.)	ASTM C 907
Tensile Strength (tape)	50 psi min.	ASTM D 412
Elongation (tape)	> 1000%	ASTM D 412
Specific Gravity	0.97	ASTM D 71
Adhesive Strength		
Peel Strength on EPDM *		5 pli @ 70°F
Shear Strength on EPDM *		12 psi @ 70°F
Peel Strength on TPO *		8 pli @ 70°F
Shear Strength on TPO *		15psi @ 70°F
Peel Strength on Mod-Bit		5 pli @ 70°F
Shear Strength on Mod-Bit		30 psi @ 70°F
Peel Strength on PVDF Coated Metal		12 pli @ 70°F
Shear Strength on PVDF Coated Metal		15 psi @ 70°F
Application Properties		
Service Temperature	-40°F to 250°F	ASTM D 3359
Application Temp.:	40°F to 120°F	ASTM C 603
Storage Temperature:	68°F to 120°F	ASTM D 1337
Minimum Shelf Life:	Two Years	ASTM D 1337
*Primed with ADCO PVP 100 High Solids Primer		
Peel and shear values obtained using ASTM D 413 and ASTM D 816.		
NOTE: The foregoing information is published as general information only. The listed properties and performance characteristics are approximate values and are not part of the product specification.		

ADCO Products, Inc., 4401 Page Avenue, Michigan Center, MI 49254 Phone: 800-248-4010 or 517-764-0334 Fax: 517-764-6697 www.adcocorp.com

LIMITED WARRANTY: ADCO Products, Inc. ("ADCO") warrants its products to meet its published physical properties at the time of sale when tested according to ADCO's standards. If a product is proven to be defective, ADCO will, at its option, replace the defective product or refund the purchase price. ADCO shall not be liable for damages in excess of the purchase price. Any and all claims that a product is defective must be made in writing within thirty (30) days after discovery of the defect and in no event more than one (1) year after the original shipment of the product by ADCO. Failure to notify ADCO of any claim constitutes an irrevocable waiver of such claim regardless of the circumstances. THIS LIMITED WARRANTY IS THE USER'S SOLE AND EXCLUSIVE REMEDY (AND THE SOLE AND EXCLUSIVE LIABILITY OF ADCO) AND IS IN LIEU OF ANY AND ALL OTHER WARRANTIES, WRITTEN OR ORAL, STATUTORY, EXPRESS OR IMPLIED, INCLUDING ANY WARRANTY OF MERCHANTABILITY OR FITNESS FOR A PARTICULAR PURPOSE.

Notice: All statements and information in this publication are believed to be accurate and reliable as of the time of publication. Statements or suggestions concerning possible use of the products are made without representation or warranty that any such use is free of patent infringement and are not recommendations to infringe any patent. The user should not assume that all toxicity data and safety measures are indicated herein or that other measures may not be required. 10/01





PVA 600BT TAPE APPLICATION GUIDE

1. Substrate Evaluation

PVA 600BT adhesive is suitable for bonding PV modules to a variety of roofing substrates, including TPO, EPDM modified bitumen and metals. The age and condition of the roofing material must be evaluated prior to installation. The roofing material must not exhibit any peeling, cracking, rust, leaks or other potential failures. If it does the roof must be repaired or replaced prior to placing the PV modules. Thorough evaluation is recommended when bonding to any questionable surface. Adequate roof drainage is necessary. Avoid application to any area that exhibits ponding. Ponding leaves residues that are very hard to remove. These residues must be removed with cleaners and vigorous scrubbing to ensure adequate bonding. If cleaning damages the roof material it must be repaired and brought up to the original manufacturer's specifications. A primer for use in areas that show excessive soiling after thorough cleaning may be necessary to facilitate proper bonding and is available from ADCO Products.

2. Preparation of Substrate

All substrates must be dry and free of dirt, oils, soot, leaves and other contamination. Avoid ponding situations and assure adequate drainage.

TPO, EPDM, Coated and Uncoated Metals:

The substrate to be bonded should be cleaned with an appropriate solvent, preferably IPA (Isopropanol) no more that 30 minutes prior to bonding of PVA 600BT adhesive backed part. To ensure removal of all contaminants without leaving any residue, use Scotch-Brite™ pad followed by a clean, lint-free wiping cloth or disposable wipe (never recycled rags). Other solvents such as VM&P naphtha, heptane or methanol may be suitable for cleaning various substrates after thorough evaluation. The substrate must be thoroughly dry through evaporation of the solvent with radiant heat, hot air dryers or with time before bonding PVA 600BT adhesive backed parts. Ensure optimum substrate temperature, never below 40°F. (5°C) at application time. Assure application temperature of 40°F to 120°F (5°C to 50°C).

Modified Bitumen:

Lightly broom the surface to remove any loose aggregate being careful not to remove aggregate still bound to the surface. A leaf blower can be used to remove the loosened aggregate. Do not try to clean the substrate with solvents or apply any primer. If there is any question regarding the integrity of the roof membrane, overcoat the modified bitumen with a membrane supplier approved roof coating. Allow the coating to dry completely before applying the PV modules. Consult the coating manufacturer for proper dry times.

3M™ Solar Acrylic Foam Tape 4110

Product Description

3M™ Solar Acrylic Foam Tape 4110 features a modified acrylic adhesive on both sides of a very conformable, black acrylic foam carrier. It offers good adhesion on a broad range of substrates.

Key Benefits

- Pressure sensitive adhesive for quick application with immediate handling strength to speed assembly.
- Strength to replace liquid adhesives and mechanical fasteners in many applications.
- Neat application without the mess, ooze, and curing delay of liquid adhesives.
- Can typically tolerate differential movement in the shear plane up to 3 times its thickness.
- Bonds and seals simultaneously with durability to withstand vibration, impact, and weathering.
- Provides a clean, smooth appearance.

Slitting Tolerance

Standard slitting tolerance $\pm 1/32$ inch (± 0.8 mm).

Core Size

Available on a 3 inch ID Core (76.2 mm).







UL Component Recognition

Tape 4110 is UL listed under UL 746C category Q00W2, file number MH17478.

Note: All tapes should be thoroughly evaluated by the user under actual conditions with intended substrates to determine whether a specific tape is fit for a particular purpose and suitable for user's method of application, especially if expected use involves extreme environmental conditions.

Note: The following technical information and data should be considered representative or typical only and should not be used for specification purposes.

Typical Physical Properties

Properties	Typical Values	
Color	Black	
Thickness	Inches (mm)	0.045 (1.1)
	Tolerance	$\pm 10\%$
Adhesive Type	Modified Acrylic	
Foam Type	Very Conformable Closed Cell	
Density lb/ft ³ (kg/m ³)	37 (590)	
Release Type	PE Film	
Liner	Inches (mm)	0.005 (0.125)
	Color	Red
Dynamic Adhesion Performance		
	Unit	Value
90° Peel Adhesion	lb/in (N/100 mm)	20 (350)
Normal Tensile	lb/in ² (MPa)	90 (620)
Dynamic Overlap Shear	lb/in ² (MPa)	80 (550)
	90° Peel Adhesion – Based on ASTM D-3330 – To stainless steel, room temperature, jaw speed 12 in/min (305 mm/min). Average force to remove is measured.	
	Normal Tensile (T-Block Tensile) – ASTM D-897 – To aluminum, room temperature, 1 in ² (6.45 cm ²), jaw speed 2 in/min (50 mm/min). Peak force to separate is measured.	
	Dynamic Overlap Shear – ASTM D-1002 – To stainless steel, room temperature, 1 in ² (6.45 cm ²), jaw speed 0.5 in/min (12.7 mm/min). Peak force to separate is measured.	
Static Shear		
Weight (grams) that 1/2 square inch will hold 10,000 minutes (7 days)	72°F (22°C)	1000
	150°F (66°C)	500
	200°F (93°C)	500
	250°F (121°C)	250
Temperature Tolerance		
	Unit	Value
Short Term (Minutes, Hours)	°F (°C)	300 (149)
Long Term (Days, Weeks)	°F (°C)	250 (121)
	Static Shear – ASTM D3954 – To stainless steel, tested at various temperatures and gram loadings. 0.5 in ² (3.22 cm ²). Will hold listed weight for 10,000 minutes (approximately 7 days). Conversion: 1500 g/0.5 in ² equals 6.6 lb/in ² ; 500 g/0.5 in ² = 2.2 lb/in ² .	
	Short Term Temperature Tolerance – No change in room temperature dynamic shear properties following 4 hours conditioning at indicated temperature with 100 g/static load. (Represents minutes, hours in a process type temperature exposure).	
	Long Term Temperature Tolerance – Maximum temperature where tape supports at least 250 g load per 0.5 in ² in static shear for 10,000 minutes. (Represents continuous exposure for days or weeks).	



Application Guidelines

Temperature, humidity, pressure and cleanliness can impact the adhesion characteristics.

- **Temperature:** As temperature increases, the initial adhesion will typically increase. Suggested application temperatures are 70°F to 100°F (21°C to 38°C). Minimum application temperature is 60°F (15°C).
- **Humidity:** The suggested humidity target for the application is below 90% R.H. SAFT that has a paper liner should be kept and applied below 70% R.H. There is concern that bringing cold tape or substrates into a warm humid environment can also cause condensation, which impact adhesion.
- **Pressure:** Increasing pressure can improve the adhesive to surface contact, which can increase the adhesion. Suggested pressurization is 30 psi. Minimum suggested pressurization is 15 psi at bondline interface.
- **Cleanliness:** The cleanliness of the surface can also impact adhesion. Typically a thorough cleaning with a 50:50 mixture of isopropyl alcohol and water is sufficient.

The impact of these variables is very dependent on the specific substrate. Going outside of these ranges can have positive or negative impacts. Performance is dependent on the substrate.

See Application Techniques document for additional information.

Shelf Life

24 months from date of manufacture when stored at 40°F to 100°F (4°C to 38°C) and 0 to 95% relative humidity. The optimum storage conditions are 72°F (22°C) and 50% relative humidity.

Performance of tapes is not projected to change even after shelf life expires; however, 3M does suggest that 3M™ Solar Acrylic Foam Tapes are used prior to the shelf life date whenever possible.

Additional Typical Characteristics

Properties	Typical Values	
Thermal Conductivity – K-value	Unit	Value
BTU in	(hr ft ² °F (w/mK))	0.37 (0.05)
R-Value = thickness/K-value (When units of K-value are BTU-in/hr ft ² °F and thickness is given in inches.)		
Resistivity (ASTM D257)	Unit	Value
Volume Resistivity	(In ohm-cm)	2.5 x 10 ¹⁴
Surface Resistance	(In ohms/square)	> 10 ¹⁴

For more information on our solar manufacturing product line, contact 3M Renewable Energy at 800-755-2654 or visit us at www.3M.com/solar.

Technical Information: The technical information, recommendations and other statements contained in this document are based upon tests or experience that 3M believes are reliable, but the accuracy or completeness of such information is not guaranteed.

Product Use: Many factors beyond 3M's control and uniquely within user's knowledge and control can affect the use and performance of a 3M product in a particular application. Given the variety of factors that can affect the use and performance of a 3M product, user is solely responsible for evaluating the 3M product and determining whether it is fit for a particular purpose and suitable for user's method of application.

Warranty, Limited Remedy, and Disclaimer: Unless an additional warranty is specifically stated on the applicable 3M product packaging or product literature, 3M warrants that each 3M product meets the applicable 3M product specification at the time 3M ships the product. 3M MAKES NO OTHER WARRANTIES OR CONDITIONS, EXPRESS OR IMPLIED, INCLUDING, BUT NOT LIMITED TO, ANY IMPLIED WARRANTY OR CONDITION OF MERCHANTABILITY OR FITNESS FOR A PARTICULAR PURPOSE OR ANY IMPLIED WARRANTY OR CONDITION ARISING OUT OF A COURSE OF DEALING, CUSTOM OR USAGE OF TRADE. If the 3M product does not conform to this warranty, then the sole and exclusive remedy is, at 3M's option, replacement of the 3M product or refund of the purchase price.

Limitation of Liability: Except where prohibited by law, 3M will not be liable for any loss or damage arising from the 3M product, whether direct, indirect, special, incidental or consequential, regardless of the legal theory asserted, including warranty, contract, negligence or strict liability.



Renewable Energy Division
3M Center, Building 235-15-67
St. Paul, MN 55144-1000
1-800-755-2654
www.3M.com/solar

Please recycle. Printed in USA.
Issued: 12/10 © 3M 2010.
All rights reserved. 7526HB
98-0150-0006-4

3M is a trademark of 3M Company.
Used under license by
3M subsidiaries and affiliates.



QuickPrime™ Plus

Firestone Item Number:

- 1- Quart: W56RAC1695
- 1- Gallon: W563587041
- 3- Gallon: W563587044

DESCRIPTION:

QuickPrime Plus is designed to clean and prime RubberGard™ EPDM membrane prior to application of QuickSeam™ products where required by Firestone Specifications and Details.

QuickPrime Plus must be applied with a QuickScrubber™ or QuickScrubber Plus pad and handle when preparing RubberGard membrane to receive QuickSeam Tape products. It may also be used to clean membrane prior to the application of Firestone Splice Adhesive (SA-1065).

METHOD OF APPLICATION:

1. Splice surfaces must be clean, dry, and free of foreign materials and excess dusting agent. Clean with broom or rags to remove contaminants.
2. Stir QuickSeam Plus thoroughly before and during use. Apply QuickPrime Plus at the rate of 200 - 250 square feet per gallon (4.91 - 6.14 square meters per liter) per side to the splicing surfaces using the QuickScrubber or QuickScrubber Plus pad and handle.
3. Use back and forth strokes with heavy pressure along the length of the splicing area, until membrane surfaces become dark gray in color with no streaking or puddling.
4. Additional scrubbing is required at factory seams, areas of excess dusting agent, or other contaminated areas of the RubberGard membrane. Change pads every 200' (61 m).
5. When using the QuickScrubber or the QuickScrubber Plus pad and handle, factory seams require parallel as well as perpendicular application motions along the factory seam. Apply sufficient pressure on the QuickScrubber Plus pad and handle during application so the pad holder flattens to allow the total surface of the pad to contact with the RubberGard membrane.
6. Allow the surfaces to dry according to the touch-push test (usually less than 10 minutes)



7. before applying QuickSeam products or Splice Adhesive SA-1065.
8. Complete seaming procedures per Firestone's Specifications and Details.
9. Contact your Firestone Technical Coordinator at 1-800-428-4511 for specific application information.

COVERAGE RATE:

200 - 250 square feet per gallon (4.91 - 6.14 square meter per liter) for a one side application;
100-125 square feet per gallon (2.45 - 3.07 square meter per liter) for a two side application.

Coverage rates per gallon for various QuickSeam products are as follows: (Note: 1 gal = 3.78 l)
3" QuickSeam Tape: 375-450 ft (114-137 m)/gal
6" QuickSeam Tape: 180-225 ft (55-68 m) /gal
7" QuickSeam Tape: 150-200 ft (46-61 m)/gal
6" QuickSeam Batten Cover: 300-375 ft (91-114 m)/ gal
5" QuickSeam Flashing: 340-400 ft (104-122 m)/ gal

PACKAGING:

QuickPrime Plus is available in:
1-quart cans (.95 liter) can
1-gallon (3.78 liter) pail
3-gallon (11.4 liter) pail

<u>Containers:</u>	<u>Weight: lb / kg</u>
12 1-quart cans / carton	23 / 10.45
600 1-quart cans (50 ctns) / pallet	1150 / 522.7
4 1-gallon pails / carton	32 / 14.5
216 1-gallon pails (54 ctns) / pallet	1728 / 785.5
75 3-gallon pails / pallet	1658.25 / 753.35

SHELF LIFE:

- Shelf life of one year can be expected if stored in original container at temperatures between 60 °F (15.6 °C) and 80 °F (26.7 °C).
- Shelf life will be shortened if exposed to elevated temperatures.

S723-RFS-126



QuickPrime™ Plus

STORAGE:

- Store in original unopened cartons indoors at temperatures between 60 °F (15.6 °C) and 80 °F (26.7 °C).
- Do not store on the roof in direct sunlight or at temperatures above 100 °F (37.78 °C).
- When exposed to lower temperatures, restore to 60 °F (15.6 °C) and 80 °F (26.7 °C) prior to use.

PRECAUTIONARY DATA:

1. Thinning is not allowed.
2. Flammable. Keep away from fires (open flame) and other possible ignition sources during storage and use. Do not smoke when using.
3. Use only in well-ventilated areas.
4. Use of neoprene or nitrile gloves and eye protection with side shield is recommended.
5. Use only in conjunction with QuickScrubber or QuickScrubber Plus. Do not apply with rollers, brushes or rags.
6. Mix thoroughly before and during use.
7. Refer to Material Safety Data Sheet (MSDS).

PHYSICAL PROPERTIES:

<u>Property</u>	<u>Minimum Performance</u>
Base:	Synthetic Rubber Polymers
Color:	Translucent Gray
Solvents:	Heptane, Toluene
Percent Solids:	16 - 18%
Viscosity:	Very thin, free flowing
Weight: (nominal)	6.62 lb/gal (0.79 kg/L)
Specific Gravity:	0.793 Nominal (H ₂ O = 1)
Flash Point:	0.0 °F (-17.8 °C)
V.O.C. Content:	Not to exceed 5.55 lb/gal (664 g/L)

LEED INFORMATION:

Post Consumer Recycled Content: 0%
 Post Industrial Recycled Content: 0%
 Manufacturing Location: South Bend, IN

This sheet is meant to highlight Firestone's products and specifications and is subject to change without notice. Firestone takes responsibility for furnishing quality materials, which meet Firestone's published product specifications. Neither Firestone nor its representatives practice architecture. Firestone offers no opinion on and expressly disclaims any responsibility for the soundness of any structure. Firestone accepts no liability for structural failure or resultant damages. Consult a competent structural engineer prior to installation if the structural soundness or structural ability to properly support a planned installation is in question. No Firestone representative is authorized to vary this disclaimer.



Firestone Building Products Company
 250 W. 96th Street, Indianapolis, IN 46260
 Sales: (800) 428-4442 • Technical (800) 428-4511
www.firestonebpco.com

S723-RFS-126